

Owner's Manual

MOON

350 P

Preamplifier



M O O N

MOON 350P Preamplifier

Important Safety Instructions

1. Read these instructions.
2. Keep these instructions.
3. Heed all warnings.
4. Follow all instructions.
5. Do not use this apparatus near water.
6. Clean only with a dry cloth.
7. Do not block ventilation openings. Install in accordance with the manufacturer's instructions.
8. Do not install near any heat sources such as radiators, heat registers, stoves or another apparatus that produces heat.
9. Do not defeat the safety purpose of the polarized or grounding type plug. A polarized plug has two blades with one wider than the other. A grounding-type plug has two blades and a third grounding prong. The wide blade or the third prong is provided for safety. If the provided plug does not fit into the outlet, consult an electrician for replacement of the obsolete outlet.
10. Protect the power cord from being walked on or pinched, particularly at plugs, convenience receptacles, and the point where they exit from the apparatus.
11. Only use attachments and accessories specified by the manufacturer.
12.  Use only with the cart, stand, tripod, bracket, or table specified by the manufacturer or sold with the apparatus. When a cart is used, use caution when moving the cart/apparatus combination to avoid injury from tip over.
13. Unplug this apparatus during lightning storms or when unused for long periods of time.
14. Refer all servicing to qualified service personnel. Servicing is required when the apparatus has been damaged in any way, such as when the power cord or plug has been damaged; liquid has been spilled or objects have fallen into the apparatus; or the apparatus has been exposed to rain or moisture, does not operate normally, or has been dropped.
15. No naked flame sources, such as candles, should be placed on the apparatus.

WARNING: TO REDUCE THE RISK OF FIRE OR ELECTRIC SHOCK,
DO NOT EXPOSE THIS APPLIANCE TO RAIN OR MOISTURE.

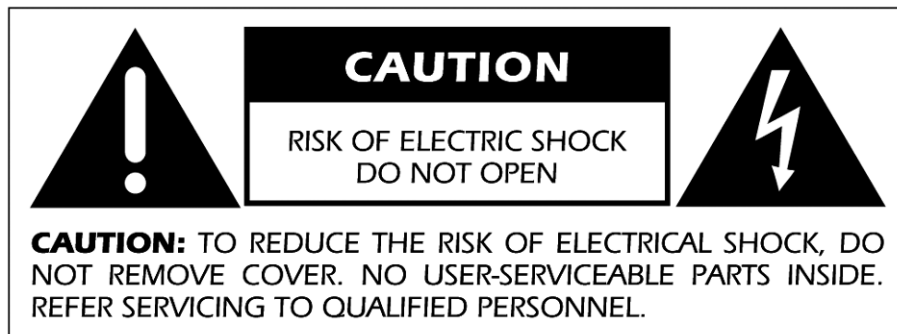

MOON 350P Preamplifier

Important Safety Instructions (cont'd)



The lightning flash with the arrowhead symbol, within an equilateral triangle, is intended to alert the user to the presence of uninsulated "dangerous voltage" within the product's enclosure that may be of sufficient magnitude to constitute a risk of electric shock to persons.



The exclamation point within an equilateral triangle is intended to alert the user to the presence of important operating and maintenance (servicing) instructions in the literature accompanying the appliance.



Marking by the "CE" symbol (shown left) indicates compliance of this device with the EMC (Electromagnetic Compatibility) and LVD (Low Voltage Directive) standards of the European Community

Please read all instructions and precautions carefully and completely before operating your Simaudio MOON 350P Preamplifier.

1. **ALWAYS** disconnect your entire system from the AC mains before connecting or disconnecting any cables, or when cleaning any component.
 2. The MOON 350P must be terminated with a three-conductor AC mains power cord which includes an earth ground connection. To prevent shock hazard, all three connections must **ALWAYS** be used. Connect the MOON 350P only to an AC source of the proper voltage; Both the shipping box and rear panel serial number label will indicate the correct voltage. Use of any other voltage will likely damage the unit and void the warranty
 3. AC extension cords are **NOT** recommended for use with this product.
 4. **NEVER** use flammable or combustible chemicals for cleaning audio components.
 5. **NEVER** operate the MOON 350P with any covers removed. There are no user-serviceable parts inside. An open unit, especially if it is still connected to an AC source, presents a potentially lethal shock hazard. Refer all questions to authorized service personnel only.
 6. **NEVER** wet the inside of the MOON 350P with any liquid. If a liquid substance enters your MOON 350P, immediately disconnect it from the AC mains and take it to your MOON dealer for a complete check-up.
 7. **NEVER** spill or pour liquids directly onto the MOON 350P.
 8. **NEVER** block air flow through ventilation slots or heatsinks.
 9. **NEVER** bypass any fuse.
 10. **NEVER** replace any fuse with a value or type other than those specified
 11. **NEVER** attempt to repair the MOON 350P. If a problem occurs contact your MOON dealer.
 12. **NEVER** expose the MOON 350P to extremely high or low temperatures.
 13. **NEVER** operate the MOON 350P in an explosive atmosphere.
 14. **ALWAYS** keep electrical equipment out of reach of children.
 15. **ALWAYS** unplug sensitive electronic equipment during lightning storms.
-

Table of Contents

Congratulations	5
Unpacking	5
Introduction	6
Installation & Placement	6
Front Panel Controls	7
Optional Digital Inputs	8
Optional Phono Section	9
Rear Panel Connections	11
Balanced Operation	12
SimLink™	13
Operating the 350P	13
Remote Control Operation	14
Specifications	15

www.simaudio.com

MOON 350P Preamplifier

Congratulations!

Thank you for selecting the **MOON 350 P** Preamplifier as a part of your music/cinema system. This component has been designed to offer state-of-the-art high-end performance in an elegant package, while retaining all the sonic hallmarks on which Simaudio has made its reputation. We have spared no effort to ensure that it is amongst *the finest* two-channel Preamplifiers available in its class. Furthermore, the numerous available options for the **MOON 350 P** make it the most versatile Preamplifier in today's marketplace.

We have been building high-performance audio equipment for 30 years, and the know-how gained through our cumulative experience is an important reason why **MOON** Preamplifiers are so musically satisfying.

The performance of your **350P** will continue to improve during the first 300 hours of listening. This is the result of a "break-in" period required for the numerous high quality electronic parts used throughout this Preamplifier.

Before setting up your new **MOON 350 P**, we encourage you to please read this manual thoroughly to properly acquaint yourself with its features. We hope you enjoy listening to the **MOON 350P** Preamplifier as much as the pride we have taken in creating this fine audio product. We understand the power and emotion of music and build our products with the goal of faithfully capturing these elusive qualities.

The information contained in this manual is subject to change without notice. The most current version of this manual is available on our official website at <http://www.simaudio.com/manuals.htm>

Unpacking

The **MOON 350P** Preamplifier should be removed from its box with care.

The following accessories should be included inside the box with your Preamplifier:

- ✓ *AC power cable*
- ✓ *'CRM' remote control with two 'AA' batteries*
- ✓ *This owner's manual*
- ✓ *Warranty and product registration information (USA and Canada only)*

As soon as the Preamplifier is safely removed from its box and placed down, perform a thorough physical inspection and report any physical damage to your dealer immediately. We suggest that you keep all of the original packaging, storing it in a safe, dry place in the event that you're required to transport the Preamplifier. The customized packaging is specially designed to protect the **MOON 350P** Preamplifier from potential damage that may occur during shipping.

Please write the serial number of your new Simaudio **MOON 350P** in the space provided below for future reference.

Serial No.: _____

MOON 350P Preamplifier

Introduction

Your **MOON 350 P** Preamplifier incorporates numerous significant design features to achieve its “world class” level of performance. This is an abbreviated list of the more important features:

An **oversized power supply** using 2 toroidal transformers in conjunction with 3 stages of DC voltage regulation

7 line-level inputs (4 Single-ended & 2 balanced) including one front-mounted 1/8" mini-jack for personal media players

One single-ended audio input which functions as a “**pass-through**”, bypassing the gain stage to accommodate a component such as a home-theater processor, whose own volume control is used instead.

A full-function **monitor loop**

Optional internal **digital-to-analog converter** circuit for use with a PC, digital music server or external transport, etc

Optional internal **phono preamp** circuit with adjustments for gain level as well as capacitance and resistance loading

Discrete headphone amplifier circuit with the output on ¼" TRS jack located on the front panel

Fixed (single-ended) and **Variable** (balanced & single-ended) **line level outputs**

Remote control operation

RS-232 port for i) full unsolicited bidirectional feedback in custom installation setups and ii) firmware updates

IR input for external control

12 Volt Trigger Output

SimLink™ controller port allows for 2-way communications between other compatible MOON components

Circuit board with **pure copper tracings and gold plating** that yields low impedance characteristics

Optimized selection of **very high quality** electronic components

Rigid chassis construction to minimize the effects of external vibrations

Designed to be **powered up at all times** for optimal performance

Low operating temperature for a longer than normal life expectancy.

Installation & Placement

The **MOON 350P** requires only minimal ventilation to maintain an optimum and consistent operating temperature. However, you should avoid placing it near a heat source as this could compromise the preamplifier's performance and reliability. As well, it should be placed on a solid level surface. The **350P** uses a toroidal transformer; even though it is well shielded, you should not place the preamplifier too close to source components sensitive to EMI, such as a turntables.

MOON 350P Preamplifier

Front Panel Controls

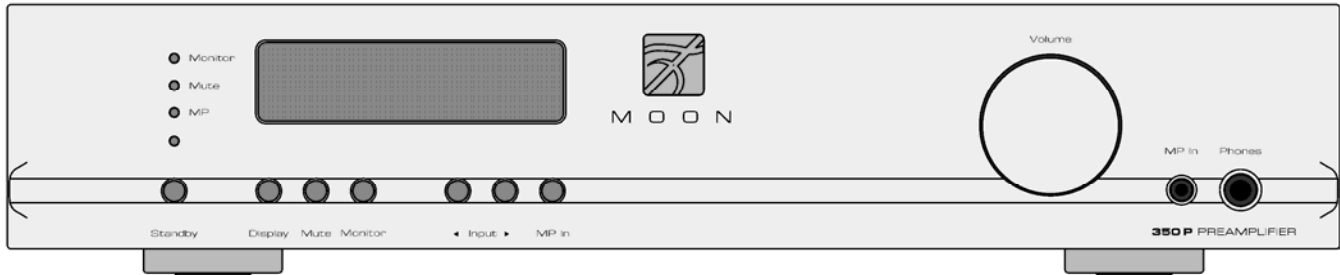

Figure 1: MOON 350P Front panel

The front panel will look similar to Figure 1 (above). The large display window indicates the selected input source. In the event that your **MOON 350P** includes the digital input option, additional information will appear in the display window. Refer to the section entitled "Optional Digital Inputs" on page 8 for further details.

Directly below the display window, from left to right, are seven (7) buttons. The "Standby" button disengages the input section from the rest of the **350P**'s circuitry. When in "Standby" mode all audio circuitry remains powered up to help maintain optimal performance. When switching back from "Standby" to the "on" mode, the blue LED directly above the button will illuminate. As well, the current 'input' will be memorized from the previous listening session. The blue indicator LED, does not illuminate when the **350P** is in "Standby" mode.

The "Display" button allows you to turn the digital display on and off. The "Mute" button mutes the output signal to both the fixed and variable line output connectors (refer to the section entitled "Rear Panel Connections" for further details), as well as the headphone jack. Pressing the "Mute" button a second time will reinstate the volume to its previous level. When the output signal is muted, the corresponding red indicator LED, located to the left of the display window, will flash on and off.

The "Monitor" button provides for a dedicated loop to be used with either a component that can record & playback (Cassette Deck, DAT, CD-Recorder, etc.) or a signal processor such as an equalizer. Pressing this button allows you to 1) monitor the recording as it occurs on the recording device or 2) engage the effects of the signal processor. The monitor component's outputs must be connected to the **350P**'s "Monitor In" and its inputs must be connected to the **350P**'s "Monitor Out". The monitor output level is fixed and independent of the **350P**'s volume setting. The LED to the left of the display window will illuminate when the "Monitor" function is engaged.

The "MP" button (for Media Player) has its corresponding input connection located on the far right side of the front panel for easy access. It uses a 1/8" mini-jack connector which is the most common type of connection found on portable media players. When selected, the corresponding red LED, located to the left of the display window, will illuminate. As well, when the "MP" input is in use the display window automatically turns off.

The two (2) buttons labeled ◀ **INPUT** ▶ allow you to sequentially scroll, either forward (▶) or backward (◀) through all of the available inputs. Depending on the installed options, the order of the inputs is as follows going forward (▶):

Basic Unit: "CD", "A1", "A2", "A3", "B1" and "B2"

All options installed: "CD", "A1", "A2", "PH", "B1", "B2", "D1", "D2", "D3" and "D4"

The above abbreviations correspond directly to the labeling of the rear panel inputs. By default the "CD" input is intended for use with a CD Player, however you can connect another type of source component to it. "A1", "A2" and "A3" are intended for use with any type of source component that outputs analog signal. If you have installed the optional phono section, the "A3" input is replaced by "PH". The balanced inouts "B1" and "B2" will appear after the "A3" / "PH" input. Finally, if you have installed the digital input option, "D1", "D2", "D3" and "D4" will appear after "B2".

MOON 350P Preamplifier

Front Panel Controls (Cont'd)

The "A2" input can be configured as a 'pass-through' which bypasses the **350P**'s gain control section, allowing you to control the gain setting via the connected source component's own volume control – a home theater processor for example; In other words, this input operates like the input of a power amplifier. In 'pass-through' mode, adjusting the volume on the **350P** will have no effect whatsoever when the "A2" input is selected. To put the "A2" input into 'pass-through' mode, press and hold down the "Monitor" button for approximately 2 seconds while on the "A2" input. The front panel display will change from "A2" to "HT". To reconfigure the "A2" input to function like the other inputs, repeat the aforementioned procedure. As well, powering down the **350P** via the rear panel rocker switch will automatically reset the "A2" to the factory default 'normal' mode.

The rotary "Volume" control determines the output level. Turning it clockwise increases the volume level and turning it counterclockwise decreases the volume level.

The "Phones" jack is used for connecting a pair of stereo headphones to the **MOON 350P**. The input connector is a standard ¼" stereo TRS jack. When a pair of headphones are used with this preamplifier, the output signal will continue to be sent to the amplifier(s) connected to the **350P**. However, for private listening press and hold down the "Mute" button for approximately 2 seconds to disable the output to your amplifier(s). The headphone amplifier circuit will continue to function and the corresponding red indicator LED, located to the left of the display window will illuminate.

Optional Digital Inputs

The Digital Input option includes four (4) separate inputs: "D1" uses an optical Toslink connector, "D2" and "D3" use S/PDIF on an female RCA connector and "D4" uses a type-B USB connector. The "D1" is intended for use with a source equipped with a TosLink digital output such as a satellite dish receiver; The "D2" and "D3" inputs are intended for use with a source equipped with a S/PDIF digital output such as a DVD player, music server or disc transport. The "D4" input is for use with a computer equipped with a USB connector and music player software such as iTunes or Winamp; you cannot connect a USB flash drive to the "D4" input.

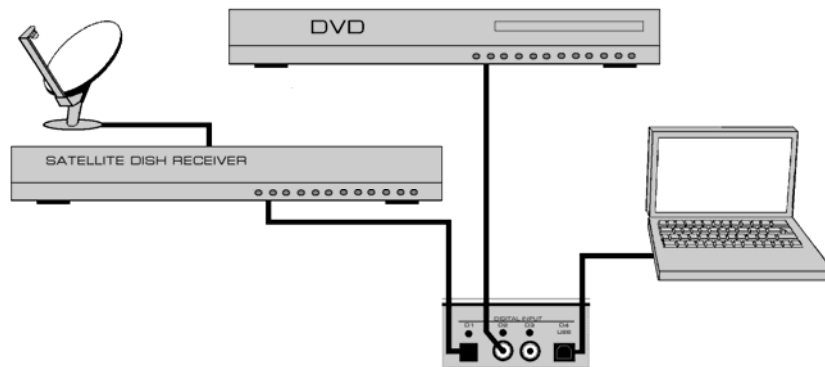

Figure 2: MOON 350P Optional Digital Inputs – connection examples

When you select one of the digital inputs as described in the aforementioned section, the display window will show which of the four digital inputs is selected. At the same time, the right side of the display window will initially show four dashes as follows "----" which indicate that the **350P** is in the process of locking onto the external digital signal – this may take several seconds. When the **350P** successfully locks onto the digital signal, the four dashes will be replaced by the sampling rate of this digital signal. When the signal cannot be locked onto, "----" remains in the display window. The optional digital-to-analog circuit option inside the **MOON 350P** is capable of processing the following six (7) different sampling rates: 44.1kHz, 48.0 kHz, 88.2kHz, 96 kHz, 176.4kHz and 192kHz.

MOON 350P Preamplifier

Optional Phono Section

The **MOON 350P** Preamplifier features an optional phono section that may be installed only at an authorized dealer or at the Simaudio factory.

Circuit Board Layout:

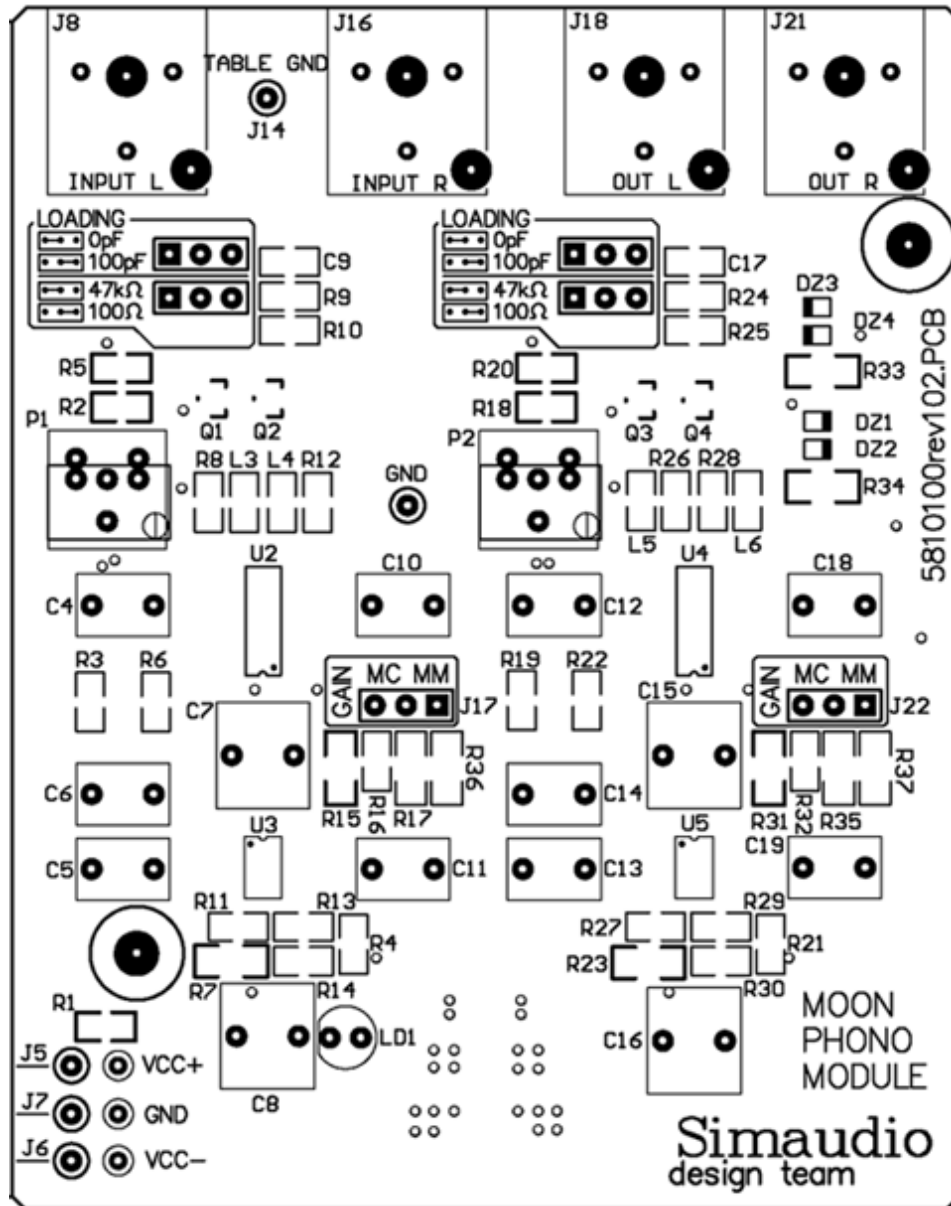

Figure 3: MOON 350P Optional Phono Section Circuit Board Layout

MOON 350P Preamplifier

Optional Phono Section (Cont'd)

Internal Settings

There are three (3) types of settings available on the optional phono section of the **MOON 350P** Preamplifier; Capacitance loading, Resistance loading, and Gain level. Each setting is adjustable through the use of jumpers. For each type of setting, there are 2 banks of jumpers – one each for the left and right channels. This is the result of the phono section's genuine mirror-image circuit design which yields exceptional stereo separation.

Always disconnect all audio connections and the AC power cord of your **MOON 350P** Preamplifier prior to changing any of the following input settings.

There are a total of six (6) screws, located on the top of the chassis, that you must remove using the included allen-key. Once these screws are removed, carefully lift off the chassis cover. Once the cover is removed, you are ready to make all of the necessary internal adjustments to the **350P** phono module to achieve optimal sonic performance.

Resistance Loading:

There are two (2) different settings available for setting the resistive load; 100 Ω and 47k Ω which are represented by jumper sockets R9 for the left channel and jumper socket R24 for the right channel (refer to figure 2 – section labeled "LOADING"). The factory default setting is 47k Ω , therefore both jumpers will be found in each of the two left most sockets.

In the event that you're using a moving magnet (MM) cartridge, it is recommended that you leave the jumpers inserted in the factory default setting of 47k Ω . Conversely, if you're using a moving coil (MC) cartridge, you should use the 100 Ω jumper settings by simply inserting the supplied jumpers into each of the two right-most sockets of jumpers R9 and R24.

Capacitance Loading:

There are two (2) different settings available for the capacitive load; 0pF and 100pF which are represented by jumper sockets C9 for the left channel and jumper sockets C17 for the right channel (refer to figure 2 – section labeled "LOADING"). The factory default setting is 100pF for a moving magnet cartridge, therefore both jumpers will be found in each of the two right most sockets.

In the event that you're using a MM cartridge, it is recommended that you leave the jumpers inserted in the factory default setting of 100pF. Conversely, if you're using a MC cartridge, you should use the 0pF jumper settings by simply inserting the supplied jumpers into each of the two left-most sockets of jumpers C9 and C17.

Gain Level:

There are two (2) different settings available for gain level. They are 40dB for MM cartridges and 60dB for MC cartridges, which are represented by jumper socket J17 for the left channel and jumper socket J22 for the right channel (refer to figure 2 – section labeled "GAIN"). The factory default setting is for a MM cartridge, therefore both jumpers will be found in each of the two right most sockets labeled MM; ***It is highly recommended that you do not use the jumpers labeled MC for an MM cartridge as this will overload the preamplifier.*** In the event that you're using a MC cartridge, you should insert the supplied jumpers into each of the two left-most sockets labeled MC.

MOON 350P Preamplifier

Rear Panel Connections



Figure 4: MOON 350P Rear panel

The rear panel will look similar to Figure 4 (above). Beginning in the upper left section, there are two (2) pairs of balanced analog inputs on XLR connectors labeled “B1” and “B2” with their respective left and right channel connections beside each other. Immediately below are four (4) pairs of single-ended analog inputs on RCA connectors labeled CD, A1, A2/HT and A3/PH. The left channel inputs are located on top and the corresponding right channel inputs are located directly below. In the event that your **MOON 350P** is equipped with the aforementioned optional phono section, the input labeled ‘A3/PH’ must be used to connect your turntable interconnect leads to this Preamplifier. If you don’t have the optional phono section installed, then this input can be used in the same way as CD, A1 and A2 inputs. As well, since “A2” can be configured as a ‘pass-through’ input, it has been labelled “A2/HT”.

This preamplifier is equipped with a single-ended monitor loop; the input and output connectors for each channel are located to the right of the four pairs of single-ended analog inputs.

The **MOON 350P** Preamplifier has one pair of balanced outputs designated for output to a power amplifier equipped with balanced inputs. It also has two pairs of single-ended outputs labeled ‘FIX’ and ‘VAR’, located next to the monitor input/output. The ‘FIX’ output is intended as an input to a recording device such as a cassette tape deck or CD-Recorder Player. Keep in mind that the output level is fixed and cannot be adjusted by the **350P**’s volume control. The ‘VAR’ output is designated for output to a power amplifier with single-ended RCA inputs; the output level is variable and is adjusted by the **350P**’s volume control.

If the power amplifier you’re connecting the **350P** to has balanced inputs, its highly advantageous to use the **350P**’s XLR outputs. This will provide you with an even better signal-to-noise ratio. Don’t hesitate to use high quality interconnects. Poor quality cables can degrade the overall sonic performance of your system.

In the event that your **MOON 350P** is equipped with the aforementioned the digital input option, you will find four (4) digital inputs labeled D1, D2, D3 and D4, located in the upper right section of the rear panel. The D1 input is on an optical Toslink connector; both the D2 and D3 inputs are on a S/PDIF connector; the D4 input is on a USB type B connector.

Below the area reserved for the optional digital inputs are a series of input/output connectors for custom type installations: From left to right there are two (2) “SimLink” connectors labeled “in” and “out” on 1/8” mini jacks. Please refer to the next section entitled SimLink™ for more details. Next, there’s a 1/8” mini-jack input for use with aftermarket infrared remote control receivers. Then there’s a 12V trigger output on a 1/8” mini-jack that can power up a connected component (with a 12V trigger input) at the same time that the **350P** is powered up. Finally, there’s a full-function bi-directional RS-232 port control and status for custom integration or automation on a DB9 connector.

MOON 350P Preamplifier

Rear Panel Connections (cont'd)

Finally on the far right side is the main power switch ("0"=off, "1"=on) and the IEC receptacle, labeled "AC Power" for the included AC power cord.

You will notice that all RCA input and output connectors on the rear panel have been color coded: 'white' for the left channel and 'red' for the right channel. A poor contact will degrade the signal substantially, and plugs and sockets should all look clean and free of dirt and corrosion. The easiest way to clean them is to remove the cables from their sockets and push them back in again. This procedure requires that your Preamplifier and the rest of your components be completely turned off. Not heeding this warning may result in serious damage to your equipment. Special contact cleaning fluids and enhancers should not be used, as they deposit a difficult to remove residue which degrades the performance of your components.

Balanced Operation

The **MOON 350 P** includes two (2) balanced line-level inputs and one (1) balanced preamplifier output on XLR connectors. The "B1" and "B2" inputs use a fully balanced differential circuit, intended for use with source components that output a fully balanced differential signal. The **MOON 350 P** balanced inputs and outputs takes full advantage of the benefits of balanced circuitry:

When using an unbalanced interconnect, the audio signal runs through both the center wire and the shield/ground wire. Any noise picked up by this interconnect (ie. nearby magnetic fields such as an AC power cord) will be reproduced by both the preamplifier and amplifier, then heard through the loudspeakers. Conversely, a balanced interconnect has three separate conductors; one for the ground and two for the actual signal. These two signals are identical except that one is 180 degrees out of phase with the other. For example, when one conductor is carrying a signal of +5 Volts, the other will be carrying a signal of -5 Volts. When these two inverted signals on a balanced line are output from the **MOON 350 P**, any noise picked up by the interconnect will be eliminated since a differential circuit amplifies only the difference between these two signals: Noise on a balanced interconnect will be equal on both conductors and therefore not be processed.

MOON 350P Preamplifier

SimLink™

The SimLink™ provides communication features between various **MOON** components. For example, if you were to connect the **CD 3.3** to the **350 P** via the SimLink™, pressing the ► (play) button on the **CD 3.3** will cause the **350 P** to automatically switch to the input labeled 'CD'. A second feature of SimLink™ involves the "Standby" function. By pressing down and holding the "Standby" button for 2 seconds on either the **CD 3.3** or **350 P**, both units will go into "Standby" mode. The same logic applies when switching from "Standby" to active mode.

The connection rules for the SimLink™ are very basic. You must always connect the supplied cable between one component's "SimLink™ Out" jack and another component's "SimLink™ In" jack. If you inadvertently connect the cable between either two "SimLink™ In" or two "SimLink™ Out" jacks, the SimLink™ communication feature will not function. Also, there is no master component in a SimLink™ chain; no one particular component operates as the main communications controller.

Operating the 350P

We recommend that you leave your **MOON 350 P** Preamplifier powered up at all times to for optimal performance. In the event that you plan to be away from your home for a few days, powering off the Preamplifier may not be a bad idea. Once fully "broken-in", please keep in mind that your **350 P** will require several hours of playing time before it reaches its peak performance after you've powered it up again.

Making the AC Connection: Connect the supplied AC power cable to the IEC receptacle, located on the rear panel of the Preamplifier's chassis. Ensure that the AC wall outlet you use has a functioning ground. For the best sonic performance, it is preferable that you plug your **MOON 350P** directly into a dedicated AC outlet and avoid using an extension cord. In order to obtain the maximum performance from your audio system, we strongly recommend that the detachable power cord not come into physical contact with any of the interconnect cables running to and from your **350 P**. In the event that this can't be avoided, you should ensure that any cables coming into contact with each other are crossed at a ninety degree angle to minimize the contact area.

Turning on your MOON 350P for the first time: Prior to turning the Preamplifier on for the first time, make sure that every cable is properly connected to avoid any problems. Then turn on your Preamplifier in the following manner:

- 1) Flick the main rocker switch labeled "POWER" to the '1' (on) position on the rear of the **350 P**.
- 2) Press the push button labeled "Standby" on the **350 P**'s front panel. The blue LED will illuminate.

On and Off Sequence: To avoid having any annoying noises (ie. "thumps" and "pops") emanate from your speakers when powering your **350 P** on or off, you should:

- 1) Always power up your **350 P** Preamplifier before powering up your amplifier.
- 2) Always power down your **350 P** after powering down your amplifier.

MOON 350P Preamplifier

Remote Control Operation

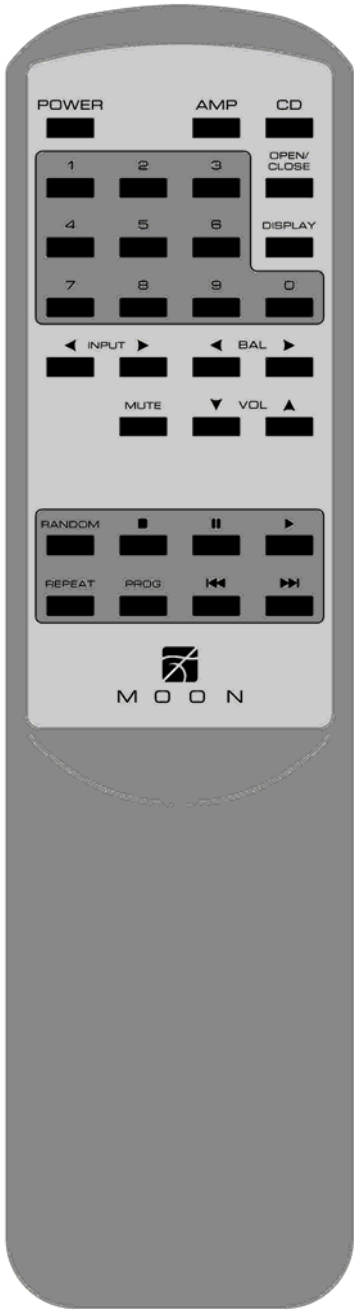

The **MOON 350P** Preamplifier uses the '**CRM**' full-function remote control (figure 3). It operates on the Philips RC-5 communication protocol and is can be used with other Simaudio MOON components.

The '**CRM**' remote uses two AA batteries (included). To install them, simply slide the back plate off in the direction of the arrow; insert the batteries in the correct direction and then replace the back plate.

To engage the CRM remote for use with the **MOON 350 P** Preamplifier, you must first press the button labeled **AMP**.

The **POWER** button located on the upper left will switch the Preamplifier to either 'Standby' or 'On' mode.

The 2 buttons labeled **◀ INPUT ▶** allow you to sequentially scroll, either backwards or forwards, through all available inputs. For example, to switch from the "A3" to the "CD" input, press **◀ INPUT** three (3) times. To switch from the "CD" to the "A3" input, press **INPUT ▶** three (3) times. Pressing and holding down either of these buttons results in only a single change to the selected input.

The 2 buttons labeled **▼ VOL ▲** allow you to control the volume level. Pressing **▼ VOL** results in a decrease in the volume level; Pressing **VOL ▲** results in an increase in the volume level. You may either press and hold these buttons down or press them briefly to make volume adjustments.

The **MUTE** button turns off the output volume. Pressing the "Mute" button a second time will reinstate the output volume level back to its current setting.

Figure 5: CRM Remote Control

MOON 350P Preamplifier

Specifications

Configuration	Fully balanced
Power Supply Transformers	1 x 10VA (for audio); 1 x 10VA (controller circuitry)
Power Supply Capacitance	26,400 μ F
Balanced inputs (XLR)	2 pairs
Single-ended inputs (RCA)	4 pairs
Mini-jack input	1 (1/8")
Monitor Loop (RCA).....	1
Input Impedance	22,000 Ω
Input Sensitivity	200mV – 10.0V RMS
Balanced outputs (XLR)	1 pair
Single-ended outputs (RCA)	2 pairs (fixed and variable)
Output Impedance	100 Ω
Gain	6dB
Signal-to-noise Ratio (20Hz-20kHz)	120dB @ full output
Maximum Output Voltage (Balanced)	16 Volts
Maximum Output Voltage (Single-Ended)	8 Volts
Audible Frequency Response	20Hz - 20kHz \pm 0.1dB
Full-Range Frequency Response	5Hz - 100kHz +0/-3.0dB
Crosstalk @ 1kHz	-96dB
Intermodulation Distortion	Unmeasurable
THD (20Hz - 20kHz)	< 0.0005%
Remote Control	Full-Function (CRM)
Power Consumption @ idle	12.5 Watts
AC Power Requirements	120V / 60Hz or 240V / 50Hz
Shipping Weight	16.5 lbs / 7.5 Kgs
Dimensions (W x H x D, inches)	16.88 x 3.5 x 13.1

Optional Phono Section:

Input Impedance	Adjustable - 100 ohms and 47K ohms
Input Capacitance	Adjustable - 0pF and 100pF
Gain	Adjustable 40dB and 60dB
Input overload @ 40dB gain	58mV RMS
Input overload @ 60dB gain	3mV RMS
Signal-to-noise Ratio (full scale @ 40dB gain)	107dB
Signal-to-noise Ratio (full scale @ 60dB gain)	85dB
Frequency Response	20Hz - 20kHz (\pm 0.5dB)
Crosstalk @ 1kHz	-97dB
IMD	< 0.009%
THD (20Hz - 20kHz)	< 0.001%

MOON 350P Preamplifier

Specifications (cont'd)

Optional Digital-to-Analog Converter:

Digital Input Types	S/PDIF (RCA) x 2	USB x 1	TosLink x 1
Digital Input Impedance (S/PDIF)	75 ohms @ 0.5 Volts		
DAC / Digital Filter	BurrBrown PCM1793		
Bit-depth range – S/PDIF, Optical	16 - 24 bits		
Bit-depth range – USB	16 bits		
Sampling Frequency Rates – S/PDIF, Optical.....	44.1, 48, 88.2, 96, 176.4 and 192kHz		
Sampling Frequency Rates – USB	44.1 and 48kHz		
Frequency Response (audible)	20Hz - 20kHz +0/-0.2dB		
Frequency Response (full range)	2Hz - 72kHz +0/-3dB		
THD @ 1kHz, 0dBFS (A-weighted)	< 0.001 %		
IMD	< 0.004 %		
Dynamic Range	> 116dB		
Signal-to-noise ratio	> 115dB @ full output		
Slew Rate	50V/ μ s		
Channel Separation	> 115dB		
Low Level Linearity	\pm 1.0dB to below 120dBFS		
Intrinsic Jitter	< 25 picoseconds RMS		

Balanced Pin Assignment: Pin 1..... Ground
Pin 2..... Positive
Pin 3 Negative

NOTE: In the event that you require the RS-232 codes for your **MOON 350 P**, please contact Simaudio Ltd. directly by either email (service@simaudio.com) or by toll-free telephone (877-980-2400).



Fuse Replacement: For the 120V version use a 0.2A fast blow (5 x 20mm size).
For the 230V version use a 0.1A fast blow (5 x 20mm size).