

Owner's Manual

MOON Series

P 5.3

Stereo Preamplifier



M O O N

MOON P 5.3 Stereo Preamplifier

Important Safety Instructions

1. Read these instructions.
2. Keep these instructions.
3. Heed all warnings.
4. Follow all instructions.
5. Do not use this apparatus near water.
6. Clean only with a dry cloth.
7. Do not block ventilation openings. Install in accordance with the manufacturer's instructions.
8. Do not install near any heat sources such as radiators, heat registers, stoves or another apparatus that produces heat.
9. Do not defeat the safety purpose of the polarized or grounding type plug. A polarized plug has two blades with one wider than the other. A grounding-type plug has two blades and a third grounding prong. The wide blade or the third prong is provided for safety. If the provided plug does not fit into the outlet, consult an electrician for replacement of the obsolete outlet.
10. Protect the power cord from being walked on or pinched, particularly at plugs, convenience receptacles, and the point where they exit from the apparatus.
11. Only use attachments and accessories specified by the manufacturer.
12.  Use only with the cart, stand, tripod, bracket, or table specified by the manufacturer or sold with the apparatus. When a cart is used, use caution when moving the cart/apparatus combination to avoid injury from tip over.
13. Unplug this apparatus during lightning storms or when unused for long periods of time.
14. Refer all servicing to qualified service personnel. Servicing is required when the apparatus has been damaged in any way, such as when the power cord or plug has been damaged; liquid has been spilled or objects have fallen into the apparatus; or the apparatus has been exposed to rain or moisture, does not operate normally, or has been dropped.
15. No naked flame sources, such as candles, should be placed on the apparatus.

WARNING: TO REDUCE THE RISK OF FIRE OR ELECTRIC SHOCK,
DO NOT EXPOSE THIS APPLIANCE TO RAIN OR MOISTURE.



MOON P5.3 Stereo Preamplifier

Important Safety Instructions (cont'd)



The lightning flash with the arrowhead symbol, within an equilateral triangle, is intended to alert the user to the presence of uninsulated "dangerous voltage" within the product's enclosure that may be of sufficient magnitude to constitute a risk of electric shock to persons.



The exclamation point within an equilateral triangle is intended to alert the user to the presence of important operating and maintenance (servicing) instructions in the literature accompanying the appliance.



Marking by the "CE" symbol (shown left) indicates compliance of this device with the EMC (Electromagnetic Compatibility) and LVD (Low Voltage Directive) standards of the European Community

Please read all instructions and precautions carefully and completely before operating your Simaudio MOON P5.3 Stereo Preamplifier.

1. **ALWAYS** disconnect your entire system from the AC mains before connecting or disconnecting any cables, or when cleaning any component.
 2. The MOON P5.3 must be terminated with a three-conductor AC mains power cord which includes an earth ground connection. To prevent shock hazard, all three connections must **ALWAYS** be used. Connect the MOON P5.3 only to an AC source of the proper voltage; Both the shipping box and rear panel serial number label will indicate the correct voltage. Use of any other voltage will likely damage the unit and void the warranty
 3. AC extension cords are **NOT** recommended for use with this product.
 4. **NEVER** use flammable or combustible chemicals for cleaning audio components.
 5. **NEVER** operate the MOON P5.3 with any covers removed. There are no user-serviceable parts inside. An open unit, especially if it is still connected to an AC source, presents a potentially lethal shock hazard. Refer all questions to authorized service personnel only.
 6. **NEVER** wet the inside of the MOON P5.3 with any liquid. If a liquid substance does enter your MOON P5.3, immediately disconnect it from the AC mains and take it to your MOON dealer for a complete check-up.
 7. **NEVER** spill or pour liquids directly onto the MOON P5.3.
 8. **NEVER** block air flow through ventilation slots or heatsinks.
 9. **NEVER** bypass any fuse.
 10. **NEVER** replace any fuse with a value or type other than those specified
 11. **NEVER** attempt to repair the MOON P5.3. If a problem occurs contact your MOON dealer.
 12. **NEVER** expose the MOON P5.3 to extremely high or low temperatures.
 13. **NEVER** operate the MOON P5.3 in an explosive atmosphere.
 14. **ALWAYS** keep electrical equipment out of reach of children.
 15. **ALWAYS** unplug sensitive electronic equipment during lightning storms.
-

Table of Contents

Congratulations	5
Unpacking and Warnings	5
Introduction	6
Installation & Placement	6
Front Panel Controls	7
Optional Phono Section	9
Rear Panel Connections	11
Operating the P5.3	12
Balanced Operation	13
Remote Control Operation	13
Specifications	14

www.simaudio.com

MOON P5.3 Stereo Preampfier

Congratulations!

Thank you for selecting the **MOON P5.3** Stereo Preampfier as a part of your music/cinema system. This component has been designed to offer state-of-the-art high-end performance in an elegant package, while retaining all the sonic hallmarks on which Simaudio has made its reputation. We have spared no effort to ensure that it is amongst *the finest* two-channel Stereo Preampfier available. We have been building high-performance audio equipment for over 25 years, and the know-how gained through our cumulative experience is an important reason why **MOON** Stereo Preampfiers are so musically satisfying.

The performance of your **P5.3** will continue to improve during the first 300 hours of listening. This is the result of a “break-in” period required for the numerous high quality electronic parts used throughout this Stereo Preampfier.

Before setting up your new **MOON P5.3**, we encourage you to please read this manual thoroughly to properly acquaint yourself with its features. We hope you enjoy listening to the **MOON P5.3** Stereo Preampfier as much as the pride we have taken in creating this fine audio product. We understand the power and emotion of music and build our products with the goal of faithfully capturing these elusive qualities.

The information contained in this manual is subject to change without notice. The most current version of this manual is available on our official website at <http://www.simaudio.com/manuals.htm>

Unpacking

The **MOON P5.3** Stereo Preampfier should be removed from its box with care.

The following accessories should be included inside the box with your Stereo Preampfier:

- ✓ *AC power cable*
- ✓ *'FRM-2' remote control with three 'AAA' batteries (USA and Canada only)*
- ✓ *Four (4) pointed screw-on tips (for the Preampfier's legs)*
- ✓ *Four (4) protective flat dimpled discs to be placed under the screw-on cones*
- ✓ *This owner's manual*
- ✓ *Warranty and product registration information (USA and Canada only)*

As soon as the Stereo Preampfier is safely removed from its box and placed down, perform a thorough physical inspection and report any physical damage to your dealer immediately. We suggest that you keep all of the original packaging, storing it in a safe, dry place in the event that you're required to transport the Stereo Preampfier. The customized packaging is specially designed to protect the **MOON P5.3** Stereo Preampfier from potential damage that may occur during shipping.

Please write the serial number of your new Simaudio **MOON P5.3** in the space provided below for future reference.

Serial No.: _____

MOON P 5.3 Stereo Preamplifier

Introduction

Your **MOON P5.3** Stereo Preamplifier incorporates many significant design features to achieve its “world class” level of performance. This is an abbreviated list of the more important features:

An **oversized power supply** using 2 toroidal transformers in conjunction with 3 stages of DC voltage regulation and extensive choke filtering

An **extremely short capacitor-free signal path** measuring only 10 inches in length, from input RCA connectors to output binding posts, for a faster transient response.

M-eVOL volume control circuit based on a resistive array configuration, resulting in no sonic degradation of the audio signal regardless of the selected volume setting

Power supply voltage regulation includes **i²DCf** (Independent Inductive DC Filtering); 1 inductor for each and every IC in the audio circuit's signal path – 14 stages in all.

IR input for external control.

12 Volt Trigger output for remote operations.

One single-ended audio input, of your choice, which functions as a “**pass-through**”, bypassing the gain stage to accommodate a component such as a home-theater processor, whose own volume control is used instead.

Optional end-user configurable phono section for both moving coil and moving magnet cartridges.

Extremely **rigid chassis construction** to minimize the effects of external vibrations.

A **symmetrical** circuit design with **accurate matching** of the very finest high quality electronic components.

Four-layer PCB tracings; The advantages include better ground and power supply circuit layouts resulting in a much shorter signal path and dramatically improved signal-to-noise ratio.

Designed to be **powered up at all times** for optimal performance.

Low operating temperature for a longer than normal life expectancy.

Installation & Placement

The **MOON P5.3** requires reasonable ventilation to maintain an optimum and consistent operating temperature. As a result, it should be placed in a location with empty space around it for proper heat dissipation. As well, it should be placed on a solid level surface. You should avoid placing it near a heat source or inside a closed cabinet that is not well ventilated as this could compromise this component's performance and reliability. The **P5.3** uses toroidal transformers; even though they are well shielded, you should not place the Stereo Preamplifier too close to source components sensitive to EMI, such as turntables and phono preamplifiers. *You should never place another component directly on top of this Stereo Preamplifier.*

Once you've decided on a location for the **P5.3**, you should install the four (4) pointed screw-on tips into the four (4) cylindrical legs of the chassis. These tips will easily scratch most surfaces, therefore it's advisable to follow these instructions: Place your **P5.3** on a soft surface (i.e. carpet) and carefully turn it so that it rests on its side. Screw one tip into each of the four legs. Carefully move the chassis to its pre-determined location. In the event that the surface you have chosen isn't perfectly level, each of the four (4) tips on your **P5.3** are height adjustable; Included with these tips is a small metal rod, intended for final adjustments (if necessary) by simply threading it through the tiny hole of each of these tips and then gently turning the tip. These adjustable screw-on tips also provide mechanical grounding of the chassis.

MOON P5.3 Stereo Preamplifier

Front Panel Controls

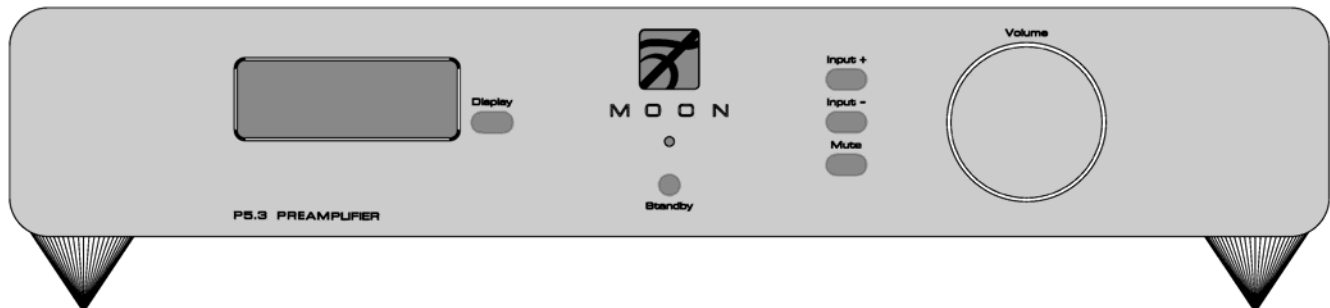

Figure 1: MOON P5.3 Front panel

The front panel will look similar to Figure 1 (above). The large display window indicates the relative gain setting (ranging from '0' through '50') for both the left and right channels. As well, whenever you change the selected input source, its number will appear in the window for 3 seconds before reverting back to the gain setting. Immediately to the right of the display window is a button labeled "Display" which allows you to turn the digital display on and off.

The "Standby/On" button disengages the input section from the rest of the **P5.3's** circuitry and turns off the digital display. However, when in "Standby" mode all audio circuitry remains powered up to help maintain optimal performance. When switching back from "Standby" to the "on" mode, both the 'input' and gain level settings will be memorized from the previous listening session. The blue pilot LED will not be illuminated when the **P5.3** is in "Stand by" mode.

The "Input +" and "Input -" buttons allow you to choose which input source you wish to listen to. The **MOON P5.3** Stereo Preamplifier has five (5) inputs; The first input is fully-balanced and uses XLR connectors labeled A1. The next four (4) inputs are single-ended and use RCA connectors labeled A2, A3, A4 and A5. Assuming that you're currently listening to a source component connected to input A1, the "+" allows to sequentially scroll forward through the available inputs from A2 to A5. The "-" button allows you to sequentially scroll backwards from A5 to A2. Holding down either the "+" or "-" button will allow only a single change of the selected input. You must press the button again to select the next or previous input.

Any one of the five inputs can be configured as a 'pass-through' which bypasses the **P5.3's** gain control section, allowing you to control the gain setting via the connected source component's own volume control – a home theater processor for example. In 'pass-through' mode, adjusting the volume on the **P5.3** will have no effect whatsoever when the 'pass-through' input is selected. By pressing and holding the "mute" button for approximately 2 seconds, the selected input will go into 'pass-through' mode; to terminate the 'pass-through' mode, simply repeat the procedure.

Only one input can be setup for 'pass-through' mode. For example, when you're listening to the source component connected to the A3 input and the A5 input is set as a 'pass-through' mode, pressing and holding the mute button will only perform the mute function. You must to scroll to and deactivate the 'pass-through' mode on A5, scroll to the A3 input, then press and hold the mute to put it into 'pass-through' mode. The factory default is no inputs are set to 'pass-through' mode. Finally, powering down the **P5.3** via the rear panel rocker switch will reset the configured 'pass through' input back to the factory default 'normal' mode.

MOON P 5.3 Stereo Preamp

Front Panel Controls (continued)

Pressing the “Mute” button reduces the current volume to “0”. Pressing the “Mute” button a second time will reinstate the volume back to its previous level.

The rotary “volume” control determines the gain setting, which ranges from ‘0.0dB’ (no output) to ‘50.0dB’ (full output). This control does not function like a typical volume: When you rotate the dial, either clockwise to raise the volume or counter-clockwise to lower the volume, you are actually engaging a precision optical encoder which selects, via a relay network, very high quality metal-film resistors that the audio signal passes through. The result is a proprietary gain circuit, called **M-eVOL**, that doesn’t degrade the audio signal regardless of the setting, unlike all potentiometer based circuits. Furthermore, since there are no actual moving parts, this technology has a minimum life expectancy of one million rotations.

The range of fifty (50) unique gain settings is based on neither a linear nor logarithmic scale. Instead, we decided on relatively small variations for each of the lower position settings from ‘1’ to ‘35’. The variations are somewhat larger from positions ‘36’ through ‘50’. For the best possible performance, it is recommended that you don’t turn the rotary control too quickly as some gain settings will be skipped and extra rotations will be required to reach position ‘50’.

Note: To change the balance between the left and right channels, please refer to the section “Remote Control Operation”.

MOON P5.3 Stereo Preampifier

Optional Phono Section

The **MOON P5.3** Stereo Preampifier features an optional phono section that may be installed only at an authorized dealer or at the Simaudio factory.

Circuit Board Layout:

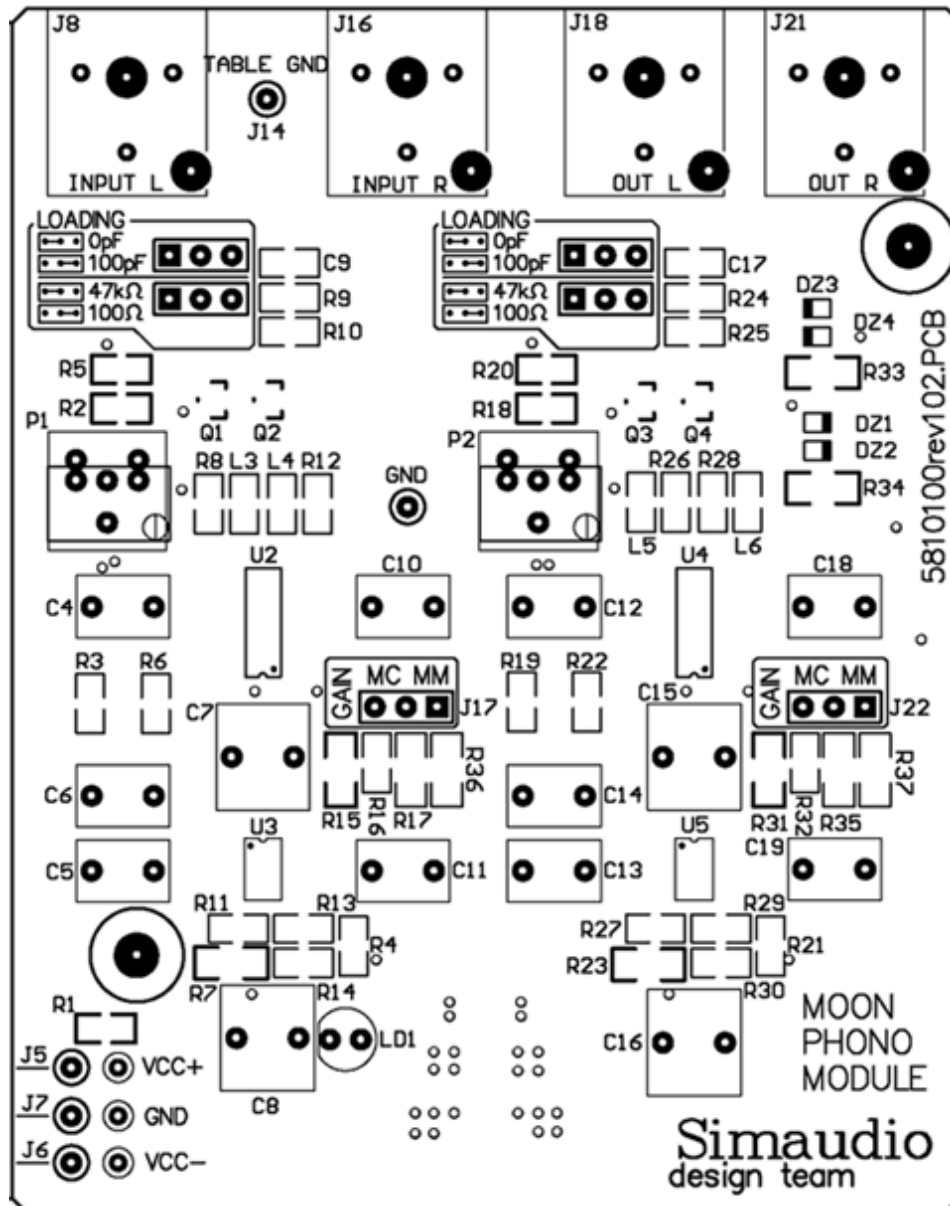

Figure 2: MOON P5.3 Optional Phono Section Circuit Board Layout

MOON P5.3 Stereo Preamp

Optional Phono Section (Cont'd)

Internal Settings

There are three (3) types of settings available on the optional phono section of the **MOON P5.3** Preamp; Capacitance loading, Resistance loading, and Gain level. Each setting is adjustable through the use of jumpers. For each type of setting, there are 2 banks of jumpers – one each for the left and right channels. This is the result of the phono section's genuine mirror-image circuit design which yields exceptional stereo separation.

Always disconnect all audio connections and the AC power cord of your **MOON P5.3** Preamp prior to changing any of the following input settings.

There are a total of six (6) screws, located on the top of the chassis, that you must remove using the included allen-key. Once these screws are removed, carefully lift off the chassis cover. Once the cover is removed, you are ready to make all of the necessary internal adjustments to the **P5.3** phono module to achieve optimal sonic performance.

Resistance Loading:

There are two (2) different settings available for setting the resistive load; 100Ω and 47kΩ which are represented by jumper sockets R9 for the left channel and jumper socket R24 for the right channel (refer to figure 2 – section labelled "LOADING"). The factory default setting is 47kΩ, therefore both jumpers will be found in each of the two left most sockets.

In the event that you're using a moving magnet (MM) cartridge, it is recommended that you leave the jumpers inserted in the factory default setting of 47kΩ. Conversely, if you're using a moving coil (MC) cartridge, you should use the 100Ω jumper settings by simply inserting the supplied jumpers into each of the two right-most sockets of jumpers R9 and R24.

Capacitance Loading:

There are two (2) different settings available for the capacitive load; 0pF and 100pF which are represented by jumper sockets C9 for the left channel and jumper sockets C17 for the right channel (refer to figure 2 – section labelled "LOADING"). The factory default setting is 100pF for a moving magnet cartridge, therefore both jumpers will be found in each of the two right most sockets.

In the event that you're using a MM cartridge, it is recommended that you leave the jumpers inserted in the factory default setting of 100pF. Conversely, if you're using a MC cartridge, you should use the 0pF jumper settings by simply inserting the supplied jumpers into each of the two right-most sockets of jumpers C9 and C17.

Gain Level:

There are two (2) different settings available for gain level. They are 40dB for MM cartridges and 60dB for MC cartridges, which are represented by jumper socket J17 for the left channel and jumper socket J22 for the right channel (refer to figure 2 – section labelled "GAIN"). The factory default setting is for a MM cartridge, therefore both jumpers will be found in each of the two right most sockets labelled MM; ***It is highly recommended that you do not use the jumpers labelled MC for an MM cartridge as this will overload the preamp.*** In the event that you're using a MC cartridge, you should insert the supplied jumpers into each of the two left-most sockets labelled MC.

MOON P5.3 Stereo Preamp

Rear Panel Connections

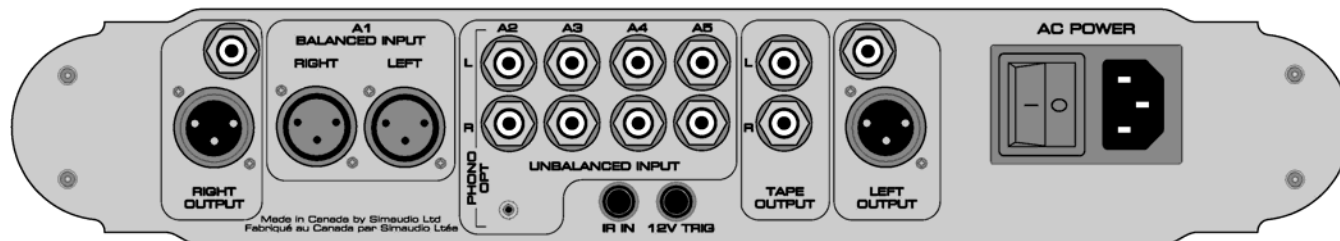

Figure 3: MOON P5.3 Rear panel

The rear panel will look similar to Figure 3 (above). There are four (4) pairs of single-ended inputs on RCA connectors labeled A2, A3, A4 and A5. The left channel inputs are located on top and the corresponding right channel inputs are located directly below. To the left of these single-ended inputs is one (1) pair of balanced inputs labeled A1.

The **MOON P5.3** Stereo Preamp has three pairs of outputs; One single-ended pair of RCA connectors and one balanced pair, each labeled 'Right Output' and "Left Output", located on either side of the previously aforementioned inputs; They are designated for output to a power amplifier with either balanced XLR or single-ended RCA inputs. A third pair of outputs, labeled "Tape Output" on single-ended RCA connectors, located directly besides the A5 input is intended as an input to a recording device such as a cassette tape deck or CD-Recordable Player. Keep in mind that the output level on the 'Tape Output' is fixed and cannot be adjusted by the **P5.3's** volume control. All RCA input and output connectors on the rear panel have been color coded: 'white' for the left channel and 'red' for the right channel.

In the event that your **MOON P5.3** is equipped with the previously described phono section module, the input labelled A2 must be used to connect your turntable interconnect leads to this preamp.

Don't hesitate to use high quality interconnects with your **MOON P5.3**. Poor quality cables can degrade the overall sonic performance of your system.

Your **MOON P5.3** is equipped with a 1/8" mini-jack input for use with aftermarket infrared remote control receivers. The "IR in" connector is centrally located directly below the single-ended inputs. To the right of this jack is another 1/8" mini-jack which is a 12 Volt trigger output intended for use with a power amplifier equipped with a 12 Volt trigger input. The purpose of this trigger is to remotely power up and down your power amplifier at the same time as your **P5.3** using its "Standby" switch.

Finally on the right side is the main power switch ("0"=off, "1"=on), the IEC receptacle, labeled "AC POWER" for the included AC power cord. Alternatively, you may use a dedicated high-performance AC power cord designed for power amplifiers.

All rear panel connectors have been chosen because they provide the best possible connections for your unit. A poor contact will degrade the signal substantially, and plugs and sockets should all look clean and free of dirt and corrosion. The easiest way to clean them is to remove the cables from their sockets and push them back in again. This procedure requires that your Stereo Preamp and the rest of your components be completely turned off. Not heeding this warning may result in serious damage to your equipment. Special contact cleaning fluids and enhancers should not be used, as they deposit a difficult to remove residue which degrades the performance of your components.

MOON P5.3 Stereo Preamp

Operating the P5.3

We recommend that you leave your **MOON P5.3** Stereo Preamp powered up at all times to maintain optimal performance. In the event that you plan to be away from your home for a few days, powering off the Stereo Preamp may not be a bad idea. Once fully "broken-in", please keep in mind that your **P5.3** will require several hours of playing time before it reaches its peak performance after you've powered it up again.

Making the AC Connection

Connect the supplied AC power cable to the IEC receptacle, located on the rear panel of the Stereo Preamp's chassis. Ensure that the AC wall outlet you use has a functioning ground. For the best sonic performance, it is preferable that you plug your **MOON P5.3** directly into a dedicated AC outlet and avoid using an extension cord.

In order to obtain the maximum performance from your audio system, we strongly recommend that the detachable power cord not come into physical contact with any of the interconnect and speaker cables running to and from your **P5.3**. In the event that this can't be avoided, you should ensure that any cables coming into contact with each other are crossed at ninety degree angle to minimize the contact area.

Turning on your MOON P5.3 for the first time

Prior to turning the Stereo Preamp on for the first time, make sure that every cable is properly connected to avoid any problems. Then turn on your Stereo Preamp in the following manner:

- 1) Flick the main rocker switch labeled "POWER" to the '1' (on) position on the rear of the **P5.3**.
- 2) Press the push button labeled "Stand by/On" on the **P5.3's** front panel. The blue LED will illuminate and the digital display will indicate a gain setting of '0' and the 'A1' as the default input.

On and Off Sequence

To avoid having any annoying noises (ie. "thumps" and "pops") emanate from your speakers when powering your **P5.3** on or off, you should

- 1) Always power up your **P5.3** preamp before powering up your amplifier.
- 2) Always power down your **P5.3** after powering down your amplifier.

MOON P 5.3 Stereo Preamplifier

Balanced Operation

When using an unbalanced interconnect, the audio signal runs through both the center wire and the shield/ground wire. Any noise picked up by this interconnect (ie. nearby magnetic fields such as an AC power cord) will be reproduced by both the preamplifier and amplifier, then heard through the loudspeakers. Conversely, a balanced interconnect has three separate conductors; one for the ground and two for the actual signal. These two signals are identical except that one is 180 degrees out of phase with the other. For example, when one conductor is carrying a signal of +10 Volts, the other will be carrying a signal of -10 Volts. When these two inverted signals on a balanced line are output from the **MOON P5.3**, any noise picked up by the interconnect will be eliminated since a differential circuit amplifies only the difference between these two signals: Noise on a balanced interconnect will be equal on both conductors and therefore not be processed.

Remote Control Operation

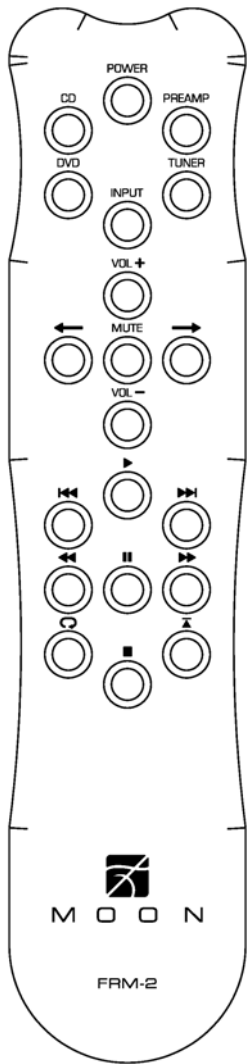

The **MOON P5.3** stereo preamplifier uses the '**FRM-2**' full function, all aluminum remote control (figure 4). It operates on the Philips RC-5 communication protocol and can be used with other MOON components.

The '**FRM-2**' remote uses three AAA batteries (included). To install them, use the supplied Allen key to remove the three screws located on the back plate; insert the batteries in the correct direction and then screw the back plate back into place.

To operate the **P5.3** with this remote control, you must first press the button labeled 'Preamp' in the top right corner.

The **POWER** button switches the **P5.3** between 'Standby' and 'On' mode.

The **INPUT** button temporarily assigns the ← and → buttons to perform the same function as the "+" and "-" input buttons located on the Preamplifier's front panel; allowing you to sequentially scroll through each of the preamplifier's inputs. After five seconds of inactivity, the ← and → buttons will again control channel balance (see below).

The **VOL+** and **VOL-** buttons increase and decrease, respectively, the volume level.

The ← and → buttons control channel balance; Pressing the left arrow button causes a decrease in the volume level of the right channel; pressing the right arrow button causes a decrease in the volume level of the right channel.

The **MUTE** button, located in the middle of the volume and balance buttons, performs the identical function as the 'Mute' button located on the **P5.3**'s front panel.

Figure 4: FRM-2 Remote Control

MOON P 5.3 Stereo Preamplifier

Specifications

Configuration	Stereo
Power Supply Transformers	1 x 10VA (for audio); 1 x 10VA (controller circuitry)
Power Supply Capacitance	26,400 μ F
Circuit Topology	Open Loop
Balanced inputs (XLR)	1 pairs
Single-ended inputs (RCA)	4 pairs
Input Impedance	22,000 Ω
Input Sensitivity	200mV – 4.0V RMS
Balanced outputs (XLR)	1 pair
Single-ended outputs (RCA)	2 pairs (fixed and variable)
Output Impedance (RCA / XLR)	50 Ω / 100 Ω
Gain Control	M-eVOL
Gain	9dB
Signal-to-noise Ratio (20Hz-20kHz)	109dB @ full output
Maximum Output Voltage (Balanced)	12 Volts
Maximum Output Voltage (Single-Ended)	6 Volts
Frequency Response	5Hz - 100kHz +0/-0.1dB
Crosstalk @ 1kHz	< -110dB
Intermodulation Distortion	Unmeasureable
THD (20Hz - 20kHz)	< 0.002%
Remote Control	All Aluminum Full-Function (FRM-2)
Power Consumption @ idle	6 Watts
AC Power Requirements	120V / 60Hz or 240V / 50Hz
Shipping Weight	25 lbs / 11 Kgs
Dimensions (W x H x D, inches)	17 x 4 x 15

Balanced Input and Output Pin Assignment:

Pin 1.....	Ground
Pin 2.....	Positive
Pin 3	Negative

Optional Phono Section:

Input Impedance - Adjustable	100 Ω and 47k Ω
Input Capacitance - Adjustable	0pF and 100pF
Gain – Adjustable	40dB and 60dB
Input overload @ 40dB/60dB gain	58mV RMS / 3mV RMS
Signal-to-noise Ratio (full scale @ 40dB/60dB gain)	107dBr / 85dBr
Frequency Response	20Hz - 20kHz (\pm 0.5dB)
Intermodulation Distortion	< 0.009%
THD (20Hz - 20kHz)	< 0.001%
Crosstalk @ 1kHz	-97dB



Fuse Replacement: For the 120V version use a 0.2A slow blow (5 x 20mm size).
For the 230V version use a 0.1A slow blow (5 x 20mm size).